

INSTALLATION INSTRUCTIONS

RECESS MOUNT BRACKET RLS-RB

CONTENTS

1 INTRODUCTION	
1-1 PRECAUTIONS	1
1-2 PARTS IDENTIFICATION	1
2 INSTALLATION AND ANGLE ADJUSTMENT	
2-1 DISASSEMBLY	1
2-2 PREPARATION	2
2-3 MOUNTING	2
2-4 ANGLE ADJUSTMENT	4
3 DIMENSIONS	
3-1 DIMENSIONS	4
4 SPECIFICATIONS	
4-1 SPECIFICATIONS	4

1 INTRODUCTION

1-1 PRECAUTIONS

- Read this instructions carefully prior to installation.
- This instructions uses the following warning indications to provide information regarding correct usage of the product to prevent harm and damages to assets. These warning indications are described below. Ensure these precautions before reading the rest of this instructions.

	Warning Failure to follow the instructions provided with this indication and improper handling may cause death or serious injury.
	Caution Failure to follow the instructions provided with this indication and improper handling may cause injury and/or property damage.

- This symbol indicates prohibition. The specific prohibited action is provided in and/or around the figure.

- This symbol requires an action or gives an instruction.

Caution

Use exclusively with the RLS-2020 series.	
When installing on a ceiling, make sure the surface is capable of withstanding the total weight of the recessed mounting kit and the RLS-2020.	
When installing on a ceiling, confirm that the thickness of the ceiling board is less than 30 mm (1.18 in.).	

1-2 PARTS IDENTIFICATION

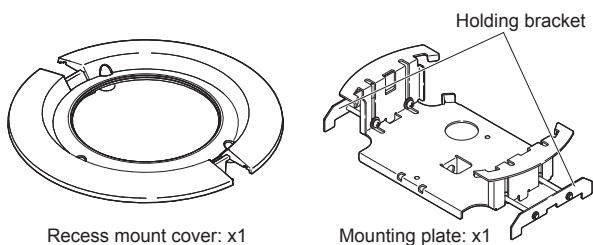

Accessories >>

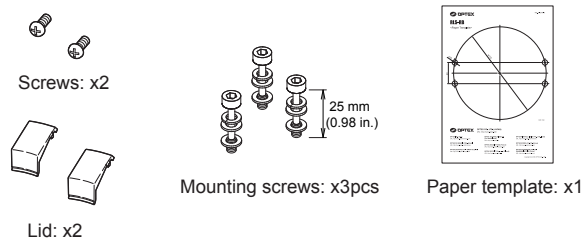

2 INSTALLATION AND ANGLE ADJUSTMENT

2-1 DISASSEMBLY

Disassemble the RLS-2020 as below.

- 1 Remove the side cover caps, side cover (L) and side covers (S).

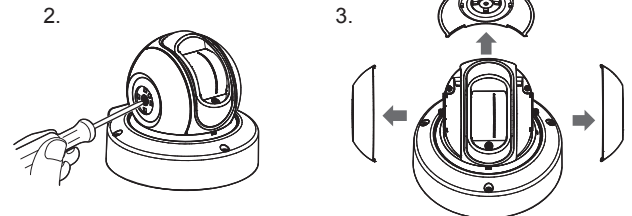
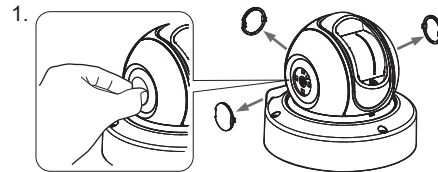

- 2 Loosen 3 screws and remove the base.

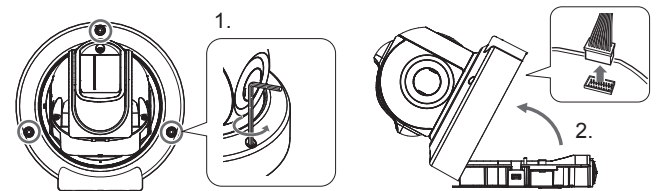

- 3 Loosen the screw on the front window and pull the front cover forward.

- 4 Rotate the front cover at opposite side of the screw upward and remove the hooks (x2).

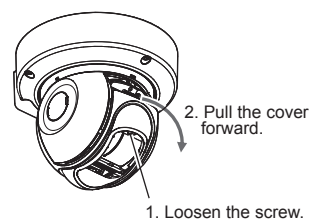

- 5 Remove the mounting bracket from the base, using a tool such as flathead screwdriver.

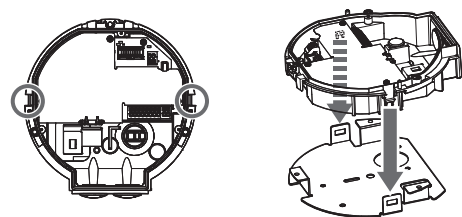

- 6 Remove the original 3 screws and separate the main unit and the base cover.

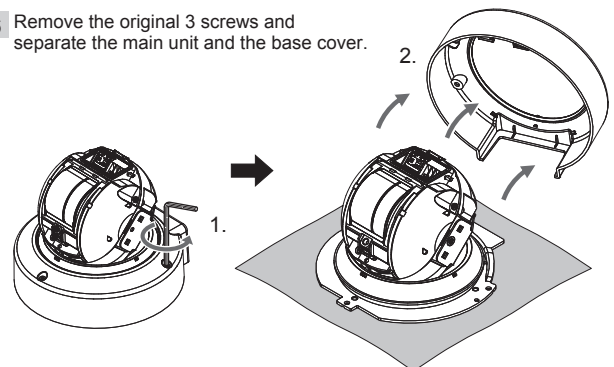

Note>>

- When remove these screws, make sure the laser window will not be damaged and soiled.
- Do not lose the screws and washers.
- Store the original mounting screws and the base cover which you removed.

2-2 PREPARATION

- 1 Attach the recess mount cover to the main unit.

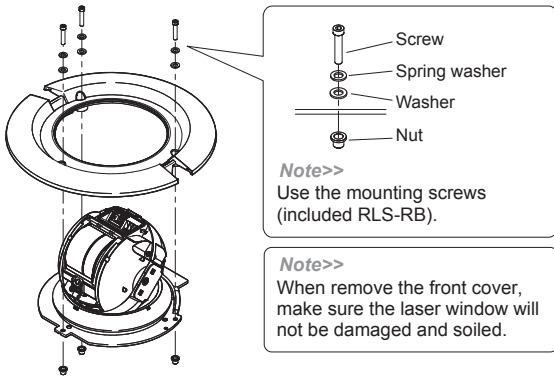

- 2 Mount the side cover (L), side cover (S) and side cover caps.

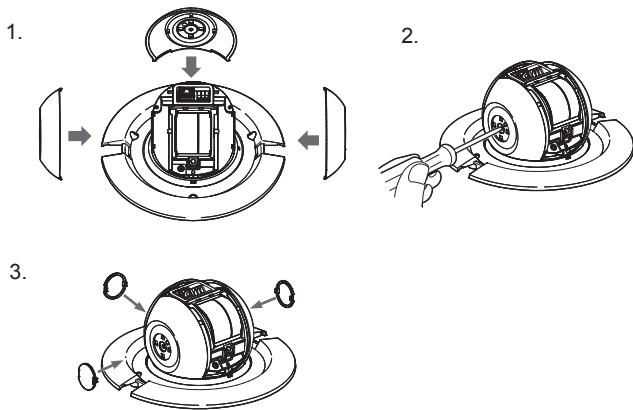

Note>>
When using the maintenance port, do not fit the front cover.

- 3 Make the knockout hole on the base with a screw-driver. Put the packing onto the back of the base as the following image.

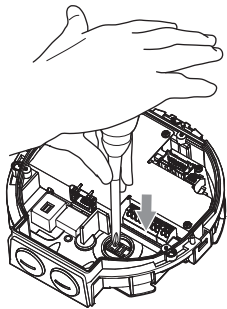

Caution >>
Be sure to open a knockout to the downward direction.

Note >>
When performing wiring on the back side, apply the packing (supplied with RLS-2020) on the depression on the back side of the base.

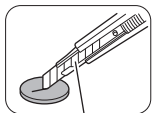

Make a slit with a cutter.

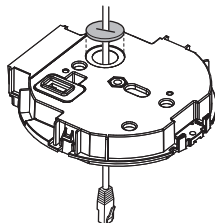

Pass the wiring through the slit of the packing.

2-3 MOUNTING

- 1 Place the supplied paper template on the mounting surface and open mounting holes.

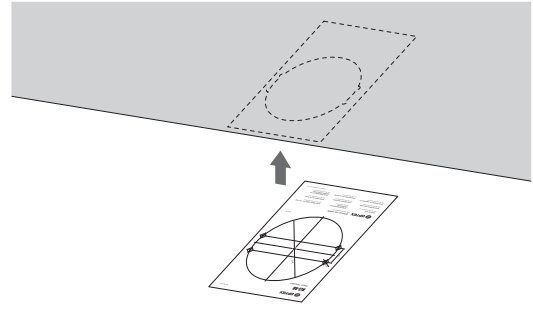

Note>> How to make the mounting hole

1. Make 4 holes of 10 mm (0.39 in.) in diameter.
2. Make a hole of 175 mm (6.89 in.) in diameter.

The ceiling holes are shown in the drawing as below.

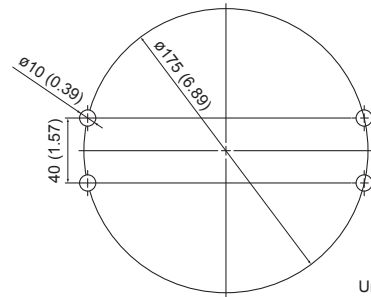

- 2 Fit the mounting bracket of RLS-2020 on the mounting plate of RLS-RB.

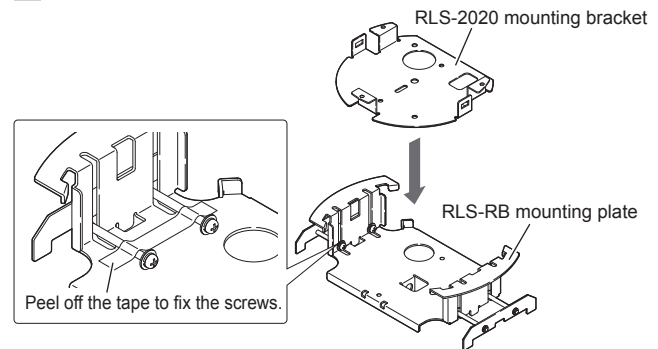

- 3 Slide the mounting bracket of RLS-2020.

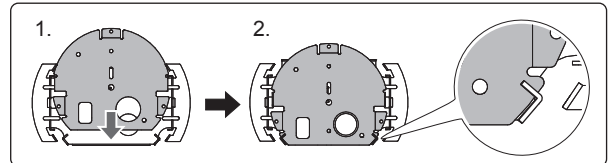
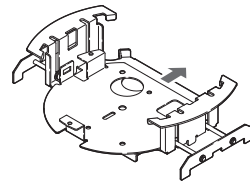

- 4 Fasten the screws to fix the mounting plate.

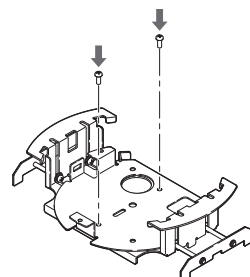

- 5 Connect safety wire (not provided) with the hole on the mounting plate. (This process is recommended.)

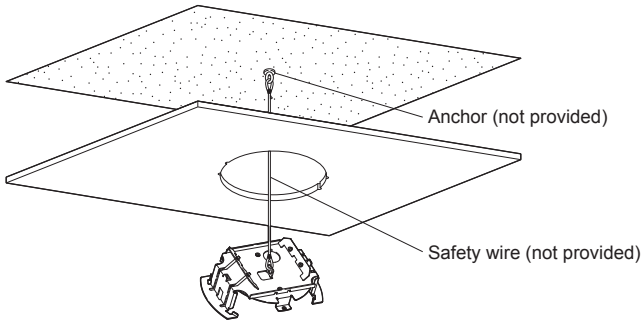

- 6 Put the mounting plate in the hole, and then slide the holding bracket to hold the ceiling between the mounting plate and the holding bracket as below. (This process is recommended.)

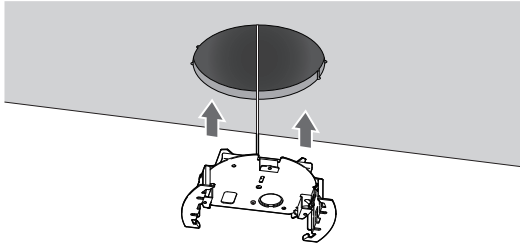

Note>> How to use the holding bracket

1. Put your hand into the ceiling hole and slide the holding bracket

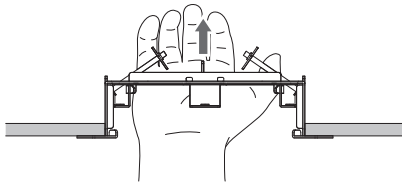

■ View from inside the ceiling

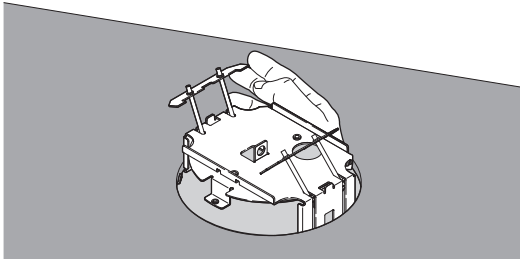

2. Hold the ceiling plate in between the holding bracket and mounting plate.

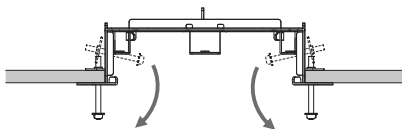

- 7 Fit the mounting plate on the ceiling and fasten the screws.

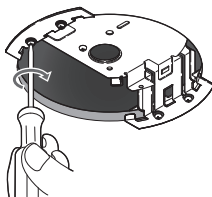

■ Side view

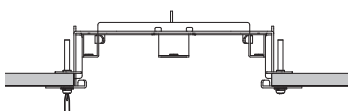

Note>>
Ceiling thickness:
8 to 30 mm (0.31 to 1.18 in.)

- 8 Pull the nylon strap.

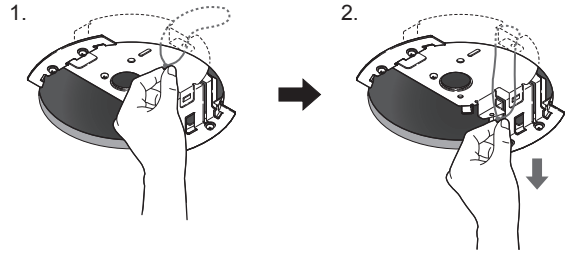

- 9 Attach the base to the mounting bracket until it clicks and pull the nylon strap.

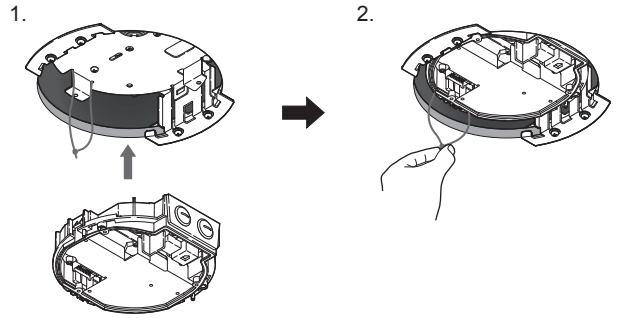

Note>>

Pull the base to make sure that the base is completely attached.

- 10 Hang the nylon strap to the hook of recess mount cover for drop-prevention as below.

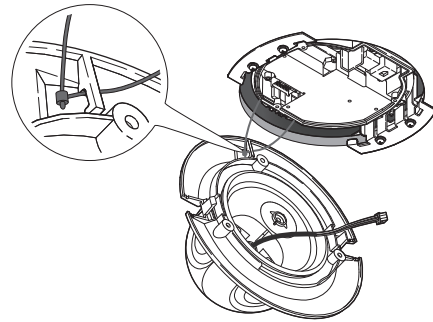

- 11 Connect the connector.

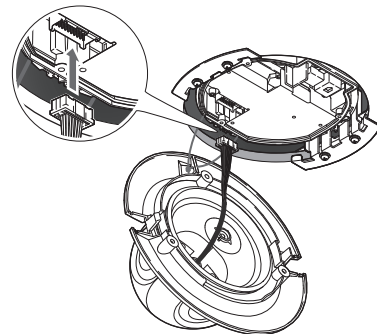

- 12 Attach the main unit to the mounting plate until it clicks.

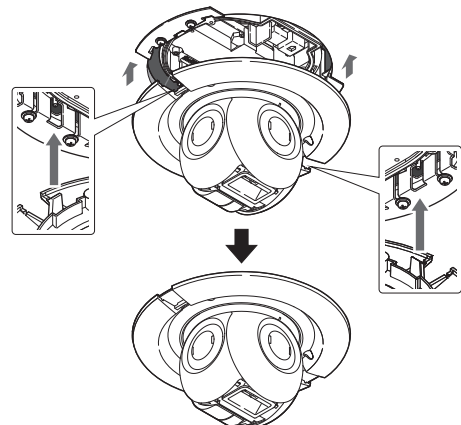

13 Fasten 3 fixing screws slightly.

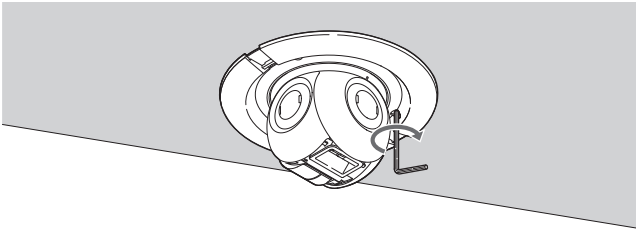

Note>>

At this moment, do not fasten the screws.
After angle adjustment, fasten them tightly.

14 Fit front cover, then put lids on the recess mount cover.

1. Fit the front cover.

2. Fasten the screw.

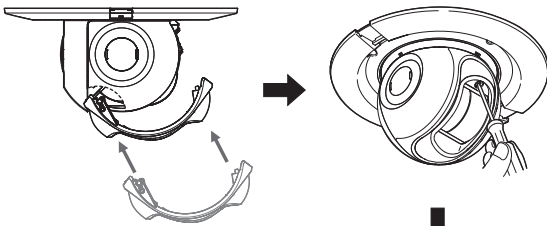

3. Put lids on the recess mount cover.

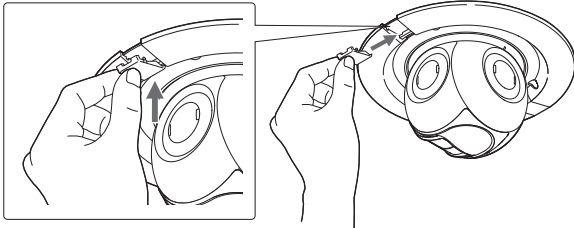

2-4 ANGLE ADJUSTMENT

Use the laser area checker (option LAC-1) to adjust the angle and then tighten 3 fixing screws.

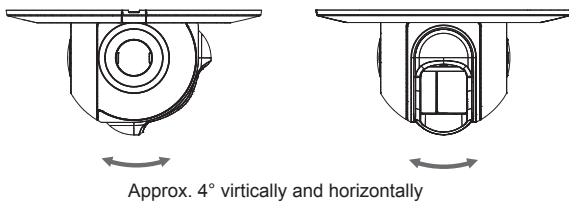
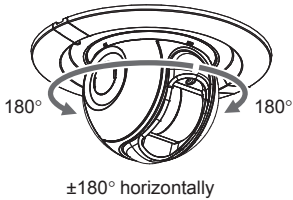

3 DIMENSIONS

3-1 DIMENSIONS

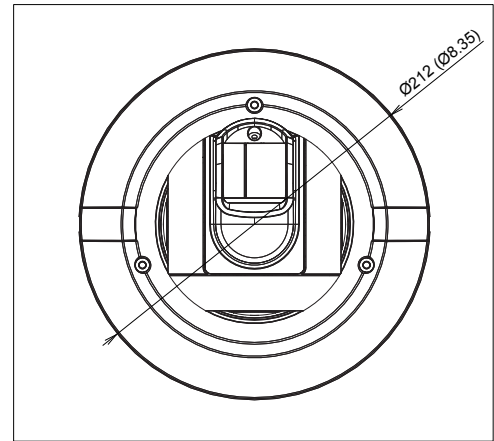
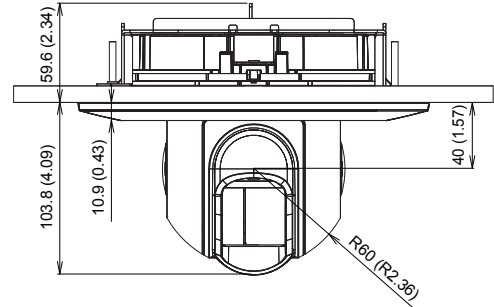

Unit: mm (inch)

4 SPECIFICATIONS

4-1 SPECIFICATIONS

Model	RLS-RB
Ceiling thickness	8 to 30 mm (0.31 to 1.18 in.)
Distance between ceiling and roof	Min. 60 mm (2.36 in.)
Weight	480 g (17 oz.) (Included RLS-2020 1400 g (49.4 oz.)
Material	Bracket: Electro galvanized steel, Recess mount cover, Lid: Polycarbonate



OPTEX CO., LTD. (JAPAN)

URL: <http://www.optex.net>

OPTEX INC. (U.S.)

URL: <http://www.optexamerica.com>

OPTEX DO BRASIL LTDA. (Brazil)

URL: <http://www.optex.net/br/es/sec>

OPTEX (EUROPE) LTD. / EMEA HQ (U.K.)

URL: <http://www.optex-europe.com>

OPTEX TECHNOLOGIES B.V. (The Netherlands)

URL: <http://www.optex.eu>

OPTEX SECURITY SAS (France)

URL: <http://www.optex-security.com>

OPTEX SECURITY Sp.z o.o. (Poland)

URL: <http://www.optex.com.pl>

OPTEX PINNACLE INDIA, PVT., LTD. (India)

URL: <http://www.optex.net/in/en/sec>

OPTEX KOREA CO.,LTD. (Korea)

URL: <http://www.optexkorea.com>

OPTEX (DONGGUAN) CO.,LTD. SHANGHAI OFFICE (China)

URL: <http://www.optexchina.com>